

MALE END VIEW

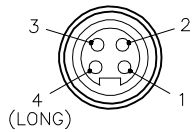

SPECIFICATIONS

HOUSING MATERIAL/COLOR	NYLON or PBT/BLACK
CONTACT MATERIAL/PLATING	BRASS/GOLD
COUPLING NUT MATERIAL/PLATING	DIECAST ZINC/NICKEL
RATED CURRENT [A]	9.0 A
RATED VOLTAGE [V]	600 V
MAXIMUM WIRE SIZE	16 AWG
TERMINATION METHOD	SCREW TERMINAL
CABLE GRIP RANGE	PG9 = 6-8mm
TEMPERATURE RATING	-25°C to +85°C (-13°F to +185°F)
PROTECTION CLASS	IP67

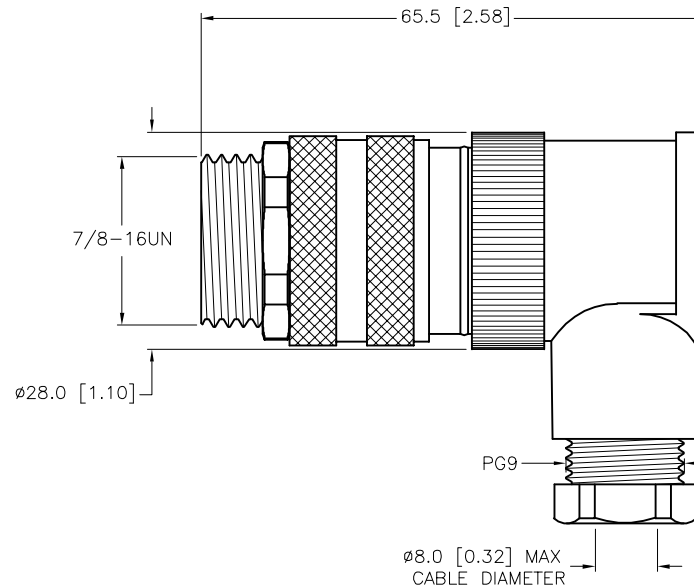
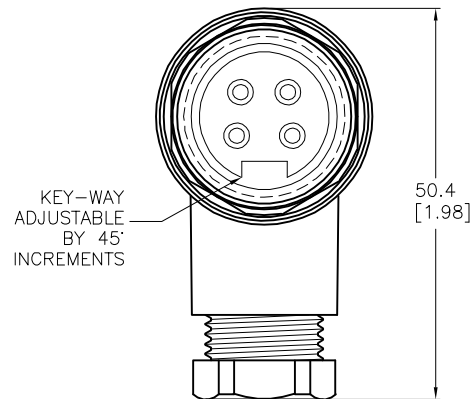

SOURCE DRAWING - FOR REFERENCE ONLY

FIELD WIREABLE MINIFAST RIGHT-ANGLE CONNECTOR

RELATED DOCUMENTS		3RD ANGLE PROJECTION		THIS DRAWING IS CONFIDENTIAL AND THE PROPERTY OF TURCK INC. USE OF THIS DOCUMENT WITHOUT WRITTEN PERMISSION IS PROHIBITED.		<p>3000 CAMPUS DRIVE MINNEAPOLIS, MN 55441 1-800-544-7769 (763) 553-7300 (763) 553-0708 fax www.turck.us</p>	
1.	2.	ALL DIMENSIONS DISPLAYED ON THIS DRAWING ARE FOR REFERENCE ONLY		DRFT	JB	DATE	07/17/00
3.	4.			APVD		SCALE	1=1.0
MATERIAL		SEE SPECIFICATIONS		UNIT OF MEASUREMENT		DESCRIPTION	
FINISH		SEE SPECIFICATIONS		MILLIMETER [ INCH ]		BS 4241-0/9	
CONTACT TURCK FOR MORE INFORMATION		DO NOT SCALE THIS DRAWING		IDENTIFICATION NO.		REV	
C ADD LONG PIN		NF 01/14/16 53066		U6419-00		C	
REV DESCRIPTION		BY DATE ECO NO.		FILE: U6419-00		SHEET 1 OF 1	